

# HOW TO ADJUST YOUR **Evo 240 Programme Chair**



## Seat Height

*(where gas lift is fitted)*  
Sit in the chair with feet firmly on the floor. Lift body weight slightly off the seat while lifting lever until a comfortable height is achieved.

## Synchron Mechanism

This mechanism is designed to follow the natural movement of the body and may be left in free float mode or locked by gently pushing down on the lever.

**Please note.** For safety the mechanism will not unlock unless the user has body weight against the back.

## Back Height-Synchron Mechanism

Hold either side of the back and gently slide upwards to fit the small of the back.

### Important

To set, lift the back ratchet all the way to the top of the adjustment (which will then unlock), then lower to the lowest position and slide upwards until you reach the desired position.

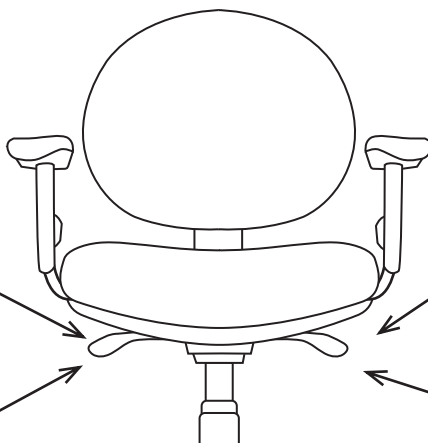

## HP Multi Function Mechanism

Upward movement of the lever releases the seat and back angle. When a comfortable posture for the task is achieved, release the lever.

## Back Height-MF Mechanism

To adjust lift the lever on the inside stem of the back upright, lift to a comfortable height and relax.

## Arm Height

*(where fitted)*  
Lift the round knob on the outside of the arm and release when the desired height is achieved.

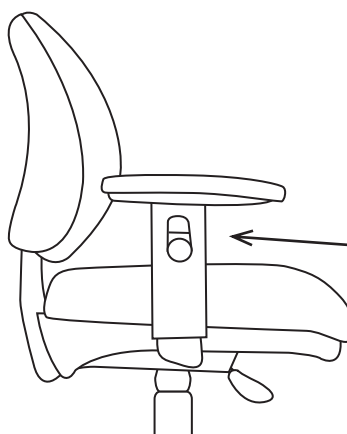

**Note that your chair may not be fitted with all options.**